

# Operation Instructions

## PE Series Super-Pressure Pump

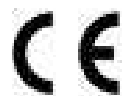

Please read these instructions carefully before operating. And keep instructions properly for future reference.



These instructions contain warnings, precautions, operation practices, and troubleshooting for PE series super-pressure pump stations.

These operation instructions are only for the reference of the end users.

## **I. Receiving Notice (Unpacking Inspection)**

Visually inspect all components for shipping damage. Shipping damage is not covered by warranty. If shipping damage is found, notify carrier at once. The carrier is responsible for all repair and replacement costs resulting from damage in shipment.

## **II. Overview**

The PE series super-pressure pump is a kind of independently integral hydraulic device assembled in integrated mode and is composed of power unit, electric units, and control devices, featuring high flow, small volume, light weight, simple structure, easy operations, high operating pressure, and high energy-saving and environmental-friendliness, with the efficiency improved by >50% than conventional single-stage pumps.

1. The motor with aluminum casing features light weight and easy heat dissipation.
2. The double-speed design shortens the working cycles and improves the productivity.
3. The built-in safety valve protects against overload.
4. It's equipped with standard pressure gauge and relief valve of adjustable pressure setting.
5. The installation of cooler is at the customer's choice.
6. The installed group valves are at the customers' choice depending on the customers' applications.
7. The standard motor starter switch only requires the turn-on of power supply.
8. The round steel protective cage protects the pump station and eases the handling and lifting.
9. The standard oil level and temperature gauge indicates the oil level and temperature.
10. Two output pressures are provided, of which the high pressure output port (port A) is fitted with high pressure relief valve adjustable within 7~70MPa and the low pressure output port (port B) is fitted with low pressure relief valve regulated at 7MPa at the time of delivery.

If equipped with corresponding tools and devices, this series pump station can fulfill the basic operations, including propelling, stretching, expansion, bending, lifting, clamping, shearing, disassembling, and press-fitting, and can also fulfill the engineering operations, including the

crimping of power transmission/transformation cables, crimping of reinforcing steel bars, pressing of reinforced concrete piles, and test of pile foundation. It can also be used as the hydraulic power source for other mechanical equipment and the pressure test pump for high pressure hoses and containers. Therefore, it's been extensively applied in all fields requiring the oil pressure energy.

### **III. Safety Instructions**

The super-pressure pump station is a kind of power source. Before use, please carefully read all instructions, warnings, and precautions and abide by the safety measures to prevent personal injuries and equipment damages during operations. SAIVS will not be liable for any damage arising from the unsafe or incorrect operations. In event of abnormality during operations, please turn off the power switch (or cut off the air source), unplug the power connector, and then consult with SAVIS or SAIVS' authorized dealer.

Please ensure to abide by the following precautions and warnings.

#### **Precautions**

1. The hydraulic pump is connected by high pressure hoses, quick couplings, and wrenches. Please use the SAIVS supplied high pressure hoses, quick couplings, and hydraulic wrenches.
2. The used scrap hydraulic oil is an industrial waste. Please have it collected and disposed by an industrial waste processing company.
3. Operating environment: Please operate this pump indoors whenever possible. For outdoors applications, ensure to take the rainproof measures. Keep the operating environment as clean and bright as possible. If the air in the operating site contains any potential explosion risk, use an explosion-proof electric pump or pneumatic pump.
4. Power supply: Please ensure that the input voltage of the hydraulic pump is consistent with the operating voltage in the site. The input power of the single-phase power supply shall be at least 3 times of the power of the pump station and the input power of three-phase power supply shall be at least 9 times of the power of the pump station.
5. Hydraulic oil selection: It's recommended to use 32# wear-resistant hydraulic oil under the environment temperature of -5~60°C. Under the environment temperature of <0°C, to prevent the hydraulic oil from freezing the pump, it's necessary to warm up the pump for 10~30min before use (Please refer to the Prestart in the operation procedure for the details of warm-up). To use this product under -5~-30°C temperature, please replace with corresponding low

trademark hydraulic oil (HV or HS series trademark).

### **Warnings**

1. During running of the hydraulic pump, all personnel must keep away from hydraulic oil outlet, in order to prevent the potential personal and property loss in event of leakage of hydraulic oil. Keep it away from fire source.
2. Before operating the pump station, ensure to install high pressure hoses and quick couplings to prevent the spray of high pressure oil from causing personal injuries.
3. The maximum operating pressure of this hydraulic pump station is 70MPa. It's prohibited to adjust the pressure beyond this value..
4. To operate other equipment by this pump station, it's necessary to adjust the pressure of this pump to the operating pressure of the equipment (The regulated pressure must be less than the maximum operating pressure of this hydraulic pump).
5. Cut off the power supply (air source) before repairs.
6. Ensure the grounding of this pump to prevent electric shock.
7. It's prohibited to start the hydraulic pump station without oil, otherwise it will cause equipment damage.
8. Adjust the relief valve to 0MPa before adjusting the pressure and ensure to increase gradually the pressure during the pressure test.
9. It's prohibited to refit this pump station. All refitting works without the written consent of SAIVS will not be covered by warranty scope. In event of special needs, please consult with SAIVS or SAIVS' authorized dealer.
10. Immediately stop using this pump station if the temperature of pump station exceeds 85°C. Wait for the pump station to cool, otherwise it will impair the life of the pump station.
11. Do not fill the oil to be above the capacity of the oil tank, otherwise the hydraulic oil will overflow to pollute the environment and equipment.
12. When the relief valve is not to be used for a long time, completely loosen the relief valve to prolong the service life of valve.
13. Ensure the complete engagement (Figure 1) while connecting the quick coupling, in order to ensure that the check valve in the connector is opened to prevent oil line blockage. Otherwise, the check valve in the connector can't be opened after connection to obstruct the oil line, in

which case the pump station is pressurized after the application of pressure and the wrench can't work to probably damage the quick coupling and wrench and even cause personal injuries. For quick coupling, directly insert the male connector into the female connector to the end and then tighten the sleeve. In such case, if the connector can't be inserted to the end, press the directional control valve to unload (Figure 11) and relieve the pressure from the connector, till the steel ball in the connector can be pushed down by hand.

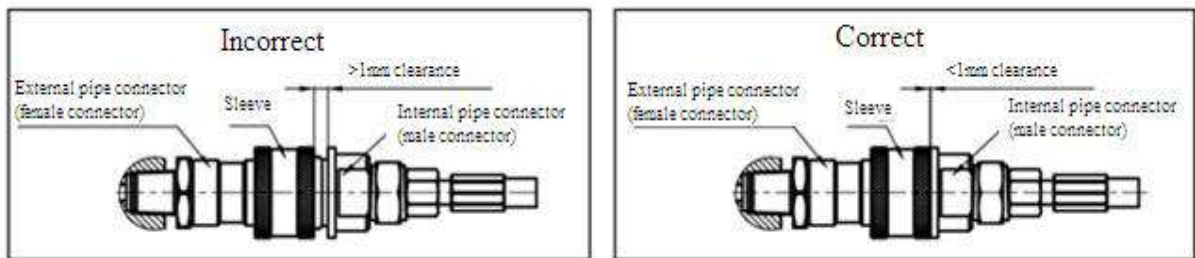
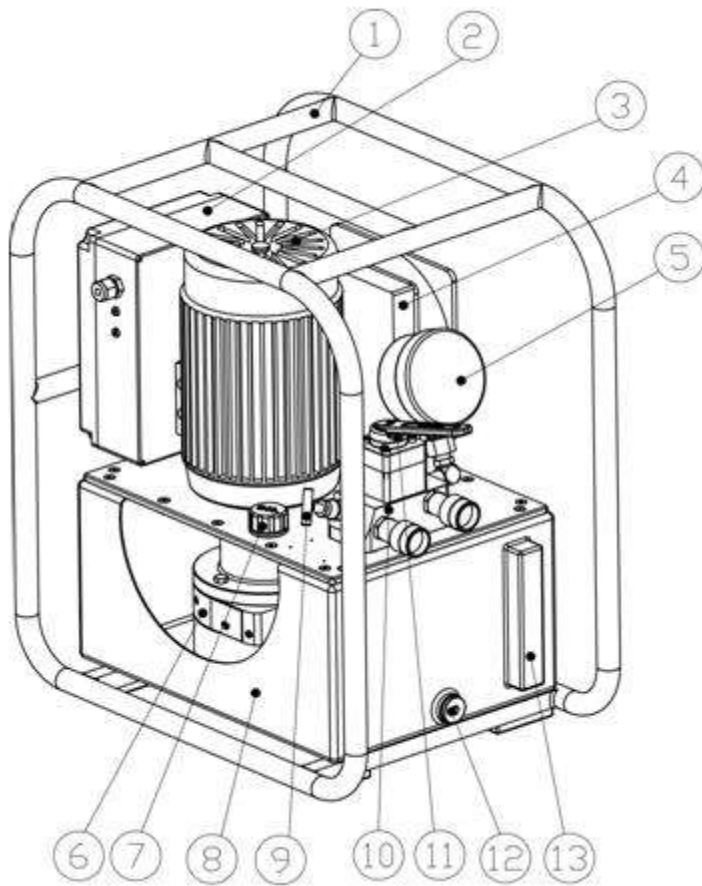

Figure (1)

14. Ensure to keep clean the hydraulic pump station, installed equipment cylinder, and internal pipeline of high pressure hoses, especially the oil outlet and the quick coupling. The dirty hydraulic oil is a main cause leading to malfunction of hydraulic pump.
15. Use 30# or 46# wear-resistant hydraulic oil for the hydraulic pump. It's prohibited to use a hydraulic oil with oil content or corrosive to the steel or aluminum.
16. In event of splash of hydraulic oil into your eyes, flush with clean water immediately for at least 15min and then seek for medical treatment.
17. The hydraulic hoses are wearing parts and are vulnerable to aging and difficult to observe. Therefore, ensure to replace the hoses periodically.
18. Keep away from all positions with possible overflow of super-pressure hydraulic oil and never touch any pressurized hose. The spray of hydraulic oil will cause serious injuries.
19. During the transport, ensure to tighten the oil filler and ventilation plug to prevent oil leakage.

#### IV. Exterior View of Pump Station and Overview of Main Parts



13	Level gauge	1
12	Drainage port	1
11	Directional control valve	1
10	Group valve	1
9	High pressure relief valve	1
8	Oil tank	1
7	Oil filler and ventilator plug	1
6	Pump head	1
5	Pressure gauge	1
4	Cooler subassembly	1
3	Motor (See nameplate for parameters)	
2	Electric box	
1	Protective cage	
No.	Name	Quantity

1. Protective cage: It's installed on the oil tank for carrying and protection of hydraulic pump.
2. Electric box: It's the electric control part of hydraulic pump to control the start of pressurization, high/low pressure switchover, and stop of pressurization of the hydraulic pump.
3. Motor: It's functioned as the power source (Choose an appropriate motor depending on the voltage and frequency of the operating site. Refer to nameplate for detailed parameters).
4. Cooler subassembly: It's functioned to reduce the oil temperature during working of oil pump (The installation of cooler is at the customer's choice).
5. Pressure gauge: This pressure gauge indicates the operating pressure of hydraulic pump, with the measurement range at 100MPa and the accuracy at 1MPa.
6. Pump head: This radial plunger pump realizes two-stage flow output.
7. Oil filler and ventilation plug: Oil filler port.
8. Oil tank: It's functioned for storage of hydraulic oil (The oil tank must contain sufficient oil).
9. Relief valve: Also referred to as pressure regulator valve, this relief valve adjusts the operating pressure of hydraulic pump (The maximum operating pressure is limited at 70MPa at the time

of delivery. It's prohibited to adjust the pressure above this maximum pressure).

10. Group valve: The diversified types of hydraulic control valves in the hydraulic system are connected to realize the control on the output and return of the hydraulic oil and guarantee the normal working of system under preset pressure (The installed group valve is at the customer's choice depending on the customer's application).
11. Directional control valve: It realizes the directional control function for output and return of high and low pressure hydraulic oil and the unloading function.
12. Drainage port: It's functioned to drain the hydraulic oil from the oil tank (during replacement of hydraulic oil).
13. Level gauge: It's functioned to observe the level of hydraulic oil, in order to guarantee the supply of the optimal oil volume.

## V. Operation Procedure

### 1. Preparations

- 1) Oil level: Check the pump oil level before start. If the oil level reaches the maximum level of the level gauge (13) (Figure 2), it indicates that the oil tank is full. When the oil level drops to the minimum level, it indicates that the oil refilling is required. In such case, open the oil filler and ventilation plug (7) and slowly add the oil of appropriate volume.

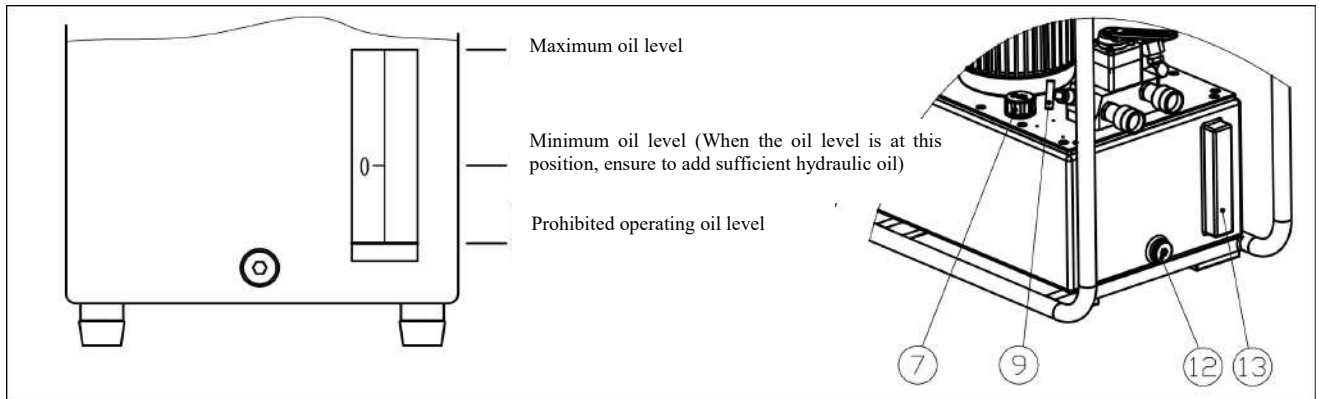

Figure (2)

- 2) Motor: Please provide the power supply as per the designated voltage on the pump nameplate or motor nameplate.

Start of motor: Connect the power supply and rotate the front face switch of electric box clockwise to [ON] position (Figure 3) to start the motor.

Stop of motor: Rotate the front face switch of electric box counter-clockwise to [OFF] position to stop the rotation of motor.

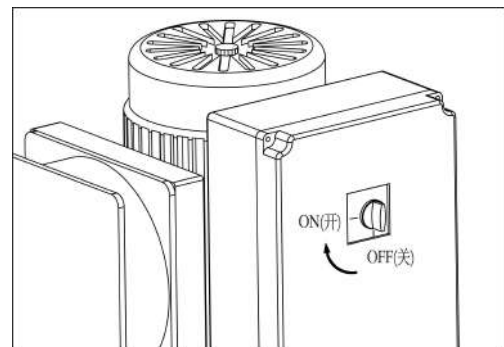

Figure (3)

- 3) Prestart: The prestart is required for the first operation, after oil replacement or long-term unused of pump station, or under cold weather. Loosen the relief valve (9) counter-clockwise to complete relief. Start the motor (or pneumatic motor) to idle the pump station for a while. After the air in the pump is completely bled and the oil pressure is stable without any abnormality, put the pump into operation. (Notice: Upon detection of any noise, immediately cut off the power supply and consult with SAIVS or SAIVS' authorized dealer).



4) Pressure regulation: The regulated pressure of the relief valve is the rated pressure of the pump station and is adjustable between 0MPa and 70MPa depending on the operating needs.

Start the motor or pneumatic motor and completely loosen the handle of relief valve (9) counter-clockwise. In such case, the pressure is almost 0. Operate the directional control valve from neutral position (Figure 5) and rotate the joystick of relief valve (9) clockwise to increase gradually the pressure to your desired value.



**Notice:** When the pump is not to be used for a long time, completely loosen the relief valve counter-clockwise to prolong the service life of valve.



**Notice:** Regulate the pressure before connecting the pump with jack and other hydraulic tools by oil hoses.

5) Connection of oil pipeline: Connect the pump station with portable oil jack or other hydraulic tool by 70MPa high pressure hoses fitted with quick couplings. The connection method is shown in Figure (4). Before the operations, ensure the proper connections of the quick couplings (Figure 1).



**Notice:** Do not connect the oil hoses while the motor is running.



**Notice:** Place the directional control valve in neutral position while connecting oil hoses.



**Notice:** Keep clean the hose connectors against the ingress of impurities into pipeline, otherwise it will lead to leakage or pipeline block and cause adverse consequence.



**Notice:** Ensure to apply the force axially during the disassembling and assembling, in order to prevent damaging O-rings or blocking the external hose connectors.



**Notice:** Do not loosen any high pressure oil hose during the running of pump.

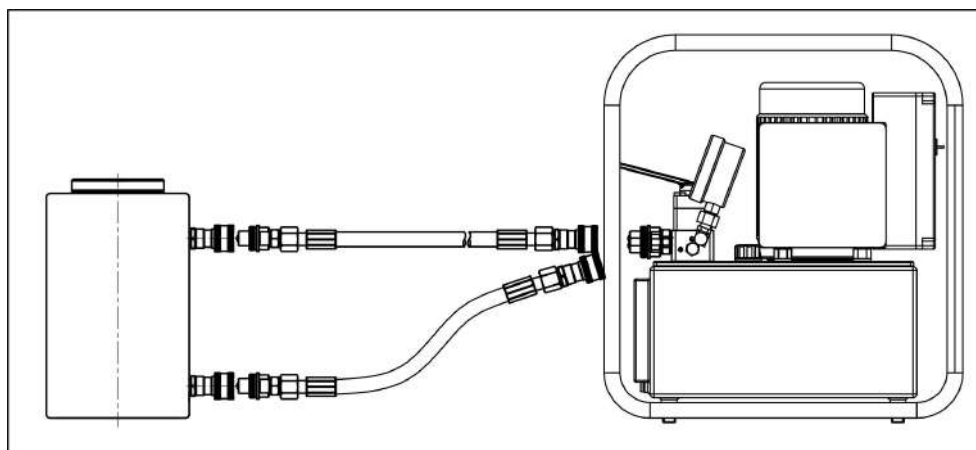

Figure (4)

6) Directional control:

Manual directional control valve: Operate the handle of directional control valve rightward to output pressure oil via port A and leftward to output pressure oil via port B and leave the handle in neutral position to drain oil via port T (Figure 5).

Solenoid directional control valve: Press and hold the button A on the handle to output pressure oil via port A, press and hold the button B on the handle to output pressure oil via port B, and release the button to unload the oil.

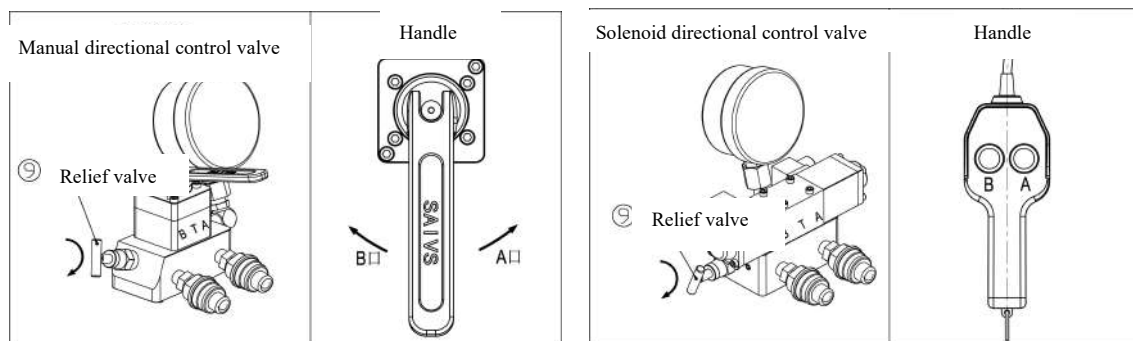

Figure (5)

## 2. Operations

- 1) At completion of above-mentioned preparations: Operate the handle of directional control valve from neutral position to the position of required oil port. In such case, if the oil outlet hose is connected with the "lower chamber" of jack, the jack lifts. When the output direction of pressure oil is changed, the jack lowers.
- 2) Completion: Operate the directional control valve to neutral position and rotate the switch of electric box to [OFF] position to stop the rotation of motor. Unplug the connector, cut off the power supply, and disassemble high pressure hoses and install the dust caps respectively.

## VI. Maintenances

1. Maintenances before operations
  - 1) Before operations, check all electric parts for presence of looseness and poor contact. If yes, repair immediately.
  - 2) Check the motor for proper grounding. Ensure that the motor is reliably grounded.
  - 3) Check whether the operating voltage in the site is within  $\pm 10\%$  of the specified voltage of the hydraulic pump and whether the voltage is stable. If the operating voltage is below the

specified voltage of the pump station, the pump station will automatically cut off power supply due to under-voltage protection.

- 4) Check whether the hydraulic oil level reaches the specified level. If insufficient, timely add hydraulic oil.
  - 5) Check the piping and equipment for presence of oil leakage. In event of oil leakage, determine the cause and treat accordingly.
  - 6) Upon detection of electric (or air) leakage in the equipment, immediately turn off the power supply and solve the malfunction before use, otherwise it will cause personal safety accidents.
2. Maintenances during operations: Upon detection of any abnormality in the following checking items, immediately stop the pump station for treatment.
- 1) Check for presence of abnormal noise, vibration, and smell and check for presence of clearly reduced speed during the working of motor (pneumatic motor).
  - 2) Check for presence of abnormality during the pressure rise.
  - 3) Check the hydraulic oil for over-high temperature.
  - 4) Check the piping and equipment for the presence of oil leakage.
  - 5) Check for serious pressure pulsation ( $>5\text{MPa}$ ).
  - 6) Check for reduced rotation speed under high pressure.
3. Maintenances after operations
- 1) Ensure to cut off the power supply (or air source) after operations.
  - 2) Check for presence of oil leakage. Upon detection of any abnormality, determine the cause and treat accordingly.
  - 3) After the operations, clean the pump station and install dust caps to quick couplings.

## **VII. Replacement of Hydraulic Oil**

1. Replace the oil after the first 100 working hours and afterwards replace the oil once every 300 working hours. Before oil replacement, fully drain the oil from the oil tank and clear up the oil tank. Under severe working environment, shorten the oil replacement interval depending on the actual conditions.

Detailed operations: Open the oil filler and ventilator plug (7) on the hydraulic pump, unscrew

the drainage plug (12) from the side drainage port of oil tank to fully drain the hydraulic oil into an appropriate container, and then clean and reinstall the drainage plug (Figure 6).

2. When necessary, disassemble the oil tank and clean the inside of oil tank and the pump head filter screen.

Detailed operations: Unscrew 18 connecting screws between oil tank cover plate and oil tank body. In such case, the entire pump head can be taken from the oil tank. Disassemble the pump head filter screen, clean the filter screen by solvent and a soft brush, and then reinstall the cleaned filter screen.

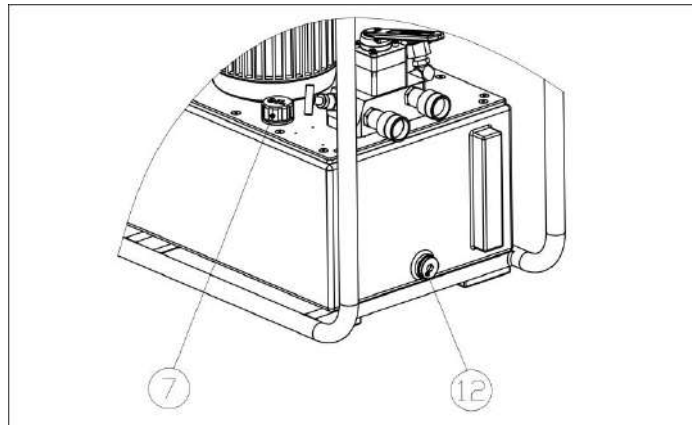

Figure (6)

## VIII. Troubleshooting

Symptom	Malfunction analysis	Solution
Start failure of pump station	1. Inconsistency between voltage and specified voltage of this pump station	1. Ensure the consistent voltage.
	2. No power supply for motor	2. Check all parts and ensure that the power supply is supplied.
	3. Damage of motor	3. Replace motor
No system pressure	1. No oil or insufficient oil in oil tank	1. Add hydraulic oil to specified level.
	2. Low pressure setting of relief valve	2. Adjust relief valve to required pressure.
	3. Blockage due to dirty oil	3. Replace hydraulic oil and clean hydraulic pump and filter screen.
	4. No oil suction of plunger pair	4. Open air bleeding valve (AIR VENT) to bleed air from pump head and ensure that the pump head is full of hydraulic oil (See Air Bleeding in Operation Procedure).
Failure of rated system pressure	1. Low pressure setting of relief valve	1. Adjust to rated pressure.
	2. Serious wear of plunger pair	2. Replace plunger pair.
	3. Serious wear of directional control valve core	3. Replace directional control valve.
	4. Damage of relief valve	4. Replace relief valve.
	5. Air content in system	5. Operate repeatedly to fully bleed air.
	6. Blockage of directional control valve by dirt	6. Clean directional control valve
Unstable system pressure	1. Dirty oil	1. Clean pump station and replace hydraulic oil.
	2. Damage of relief valve	2. Replace relief valve.
	3. Serious wear of plunger pair	3. Replace plunger pair.
	4. Air content in system	4. Operate repeatedly to fully bleed air.
	5. Blockage of directional control valve by dirt	5. Clean directional control valve

Note: If the above-mentioned problems can't be solved, please timely contact SAIVS or SAIVS' authorized dealer for troubleshooting by professionals.

## IX. Specification

□ □ □ □ □ □ □ □ □

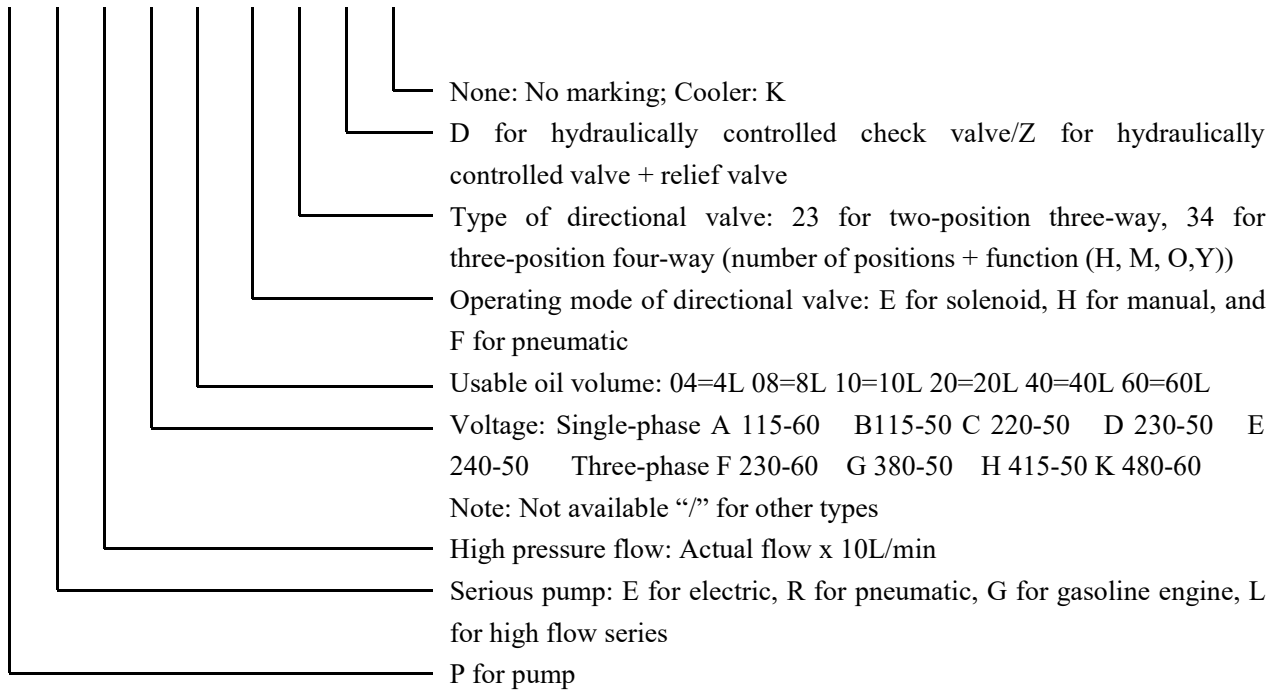

For instance: For PE10G20H34MDK super-pressure pump, the high pressure flow is 1L/min, the operating voltage is 380V 50HZ, the usable oil volume is 20L, with three-position four-way type M rotary valve, hydraulically controlled check valve, and the cooler.

Specification and model	Name	Flow (L/min)	Pressure (MPa)	Motor power (KW)	Capacity of oil tank (L)	Input power supply	Weight without oil (kg)	Overall dimensions (L×W×H, mm)
		High/low pressure	High/low pressure					
PE8	Small-sized jack pump	0.8/6.1	70/7	1.1	10	110-240V single-phase 50HZ	35	500*330*463
		0.7/7.5	70/7	1.1	10	100-130V single-phase 60HZ	35	500*330*463
PE10	Jack pump	1/6.3	70/7	1.5	28	220-440V three-phase 50HZ	50	565*385*620
	Jack pump	1/7.5	70/7	1.5	28	200-480V three-phase 60HZ	50	565*385*620

PE15	Jack pump	1.5/7	70/7	2.2	28	220-440V three-phase 50HZ	55	565*385*62 0
	Jack pump	1.5/8	70/7	2.2	28	200-480V three-phase 60HZ	55	565*385*62 0
PE25	Jack pump	2.2/9.3	70/7	3	55	220-440V three-phase 50HZ	74	605*525*79 0
	Jack pump	2.2/8.6	70/7	3	55	200-480V three-phase 60HZ	74	605*525*79 0

# X. Explosive View of Hydraulic Pump

## Assembling Explosive View of Super-Pressure Pump

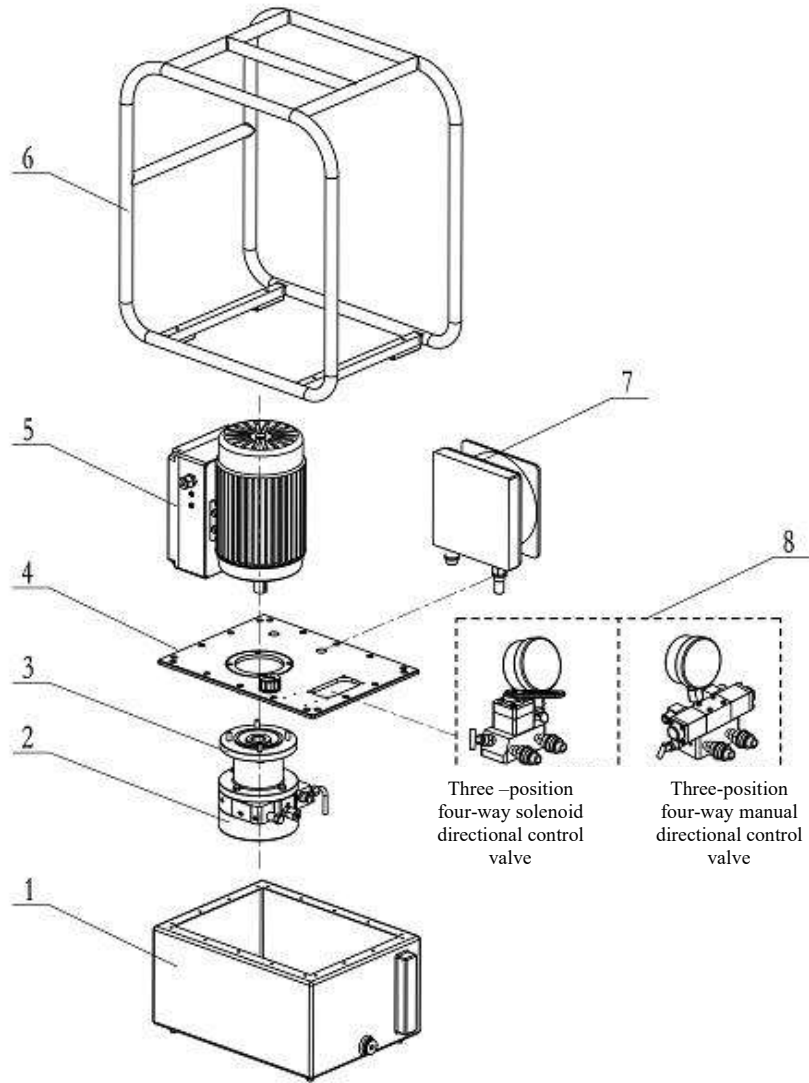

5	Electronic control system subassembly	10	
4	Oil tank cover	9	
3	Coupling	8	Integrated subassembly
2	Pump head	7	Air cooler subassembly
1	Oil tank subassembly	6	Protective cage
No.	Name	No.	Name



## Explosive View of Pump Head

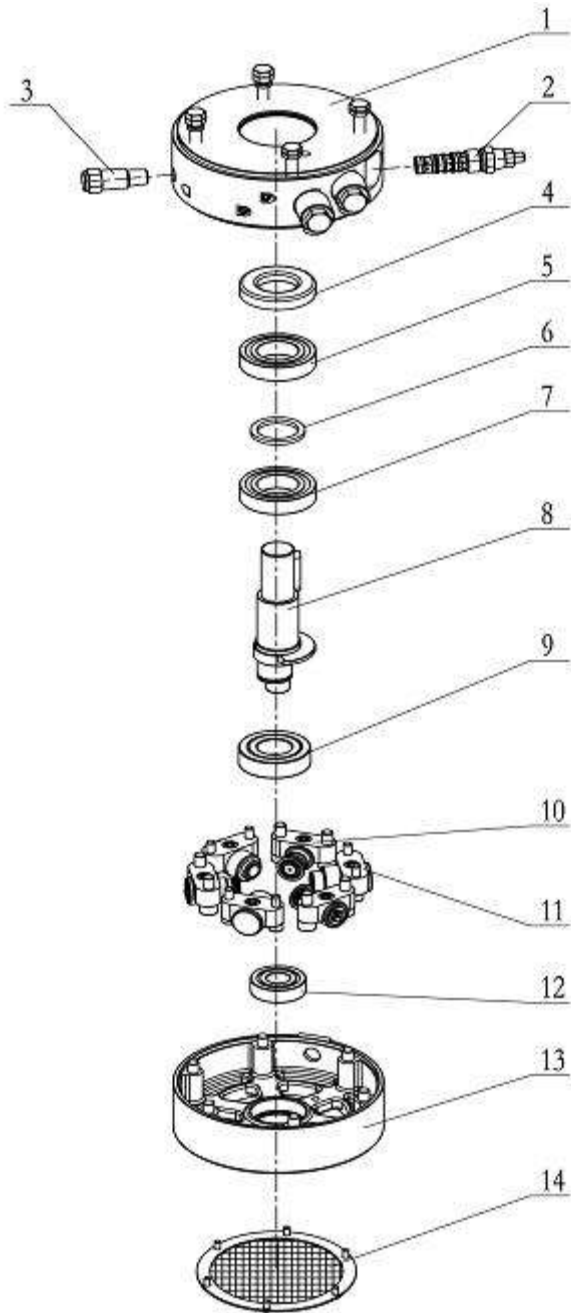

No.	Name
1	Base
2	High/low pressure switchover valve
3	Safety valve
4	TC framework oil seal
5	Deep groove ball bearing
6	Washer
7	Deep groove ball bearing
8	Crankshaft
9	Double row angular contact ball bearing
10	Plunger pair 1
11	Plunger pair 2
12	Deep groove ball bearing
13	Bearing block
14	Filter screen

## Explosive View of Three-Position Four-Way Manual Directional Control Valve

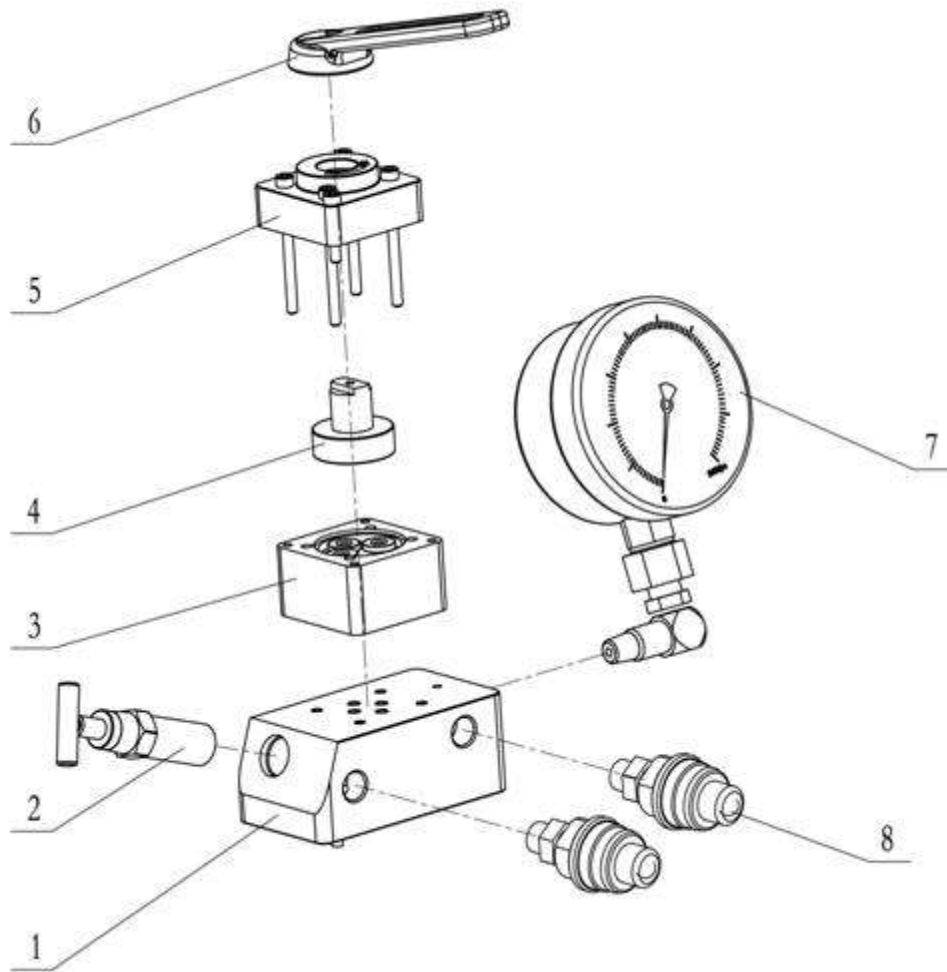

8	Male connector	16	
7	Pressure gauge	15	
6	Handle	14	
5	Pressure cap	13	
4	Distributor shaft	12	
3	Valve body	11	
2	High pressure relief valve	10	
1	Valve block	9	
No.	Name	No.	Name

## Explosive View of Three-Position Four-Way Solenoid Directional Control Valve

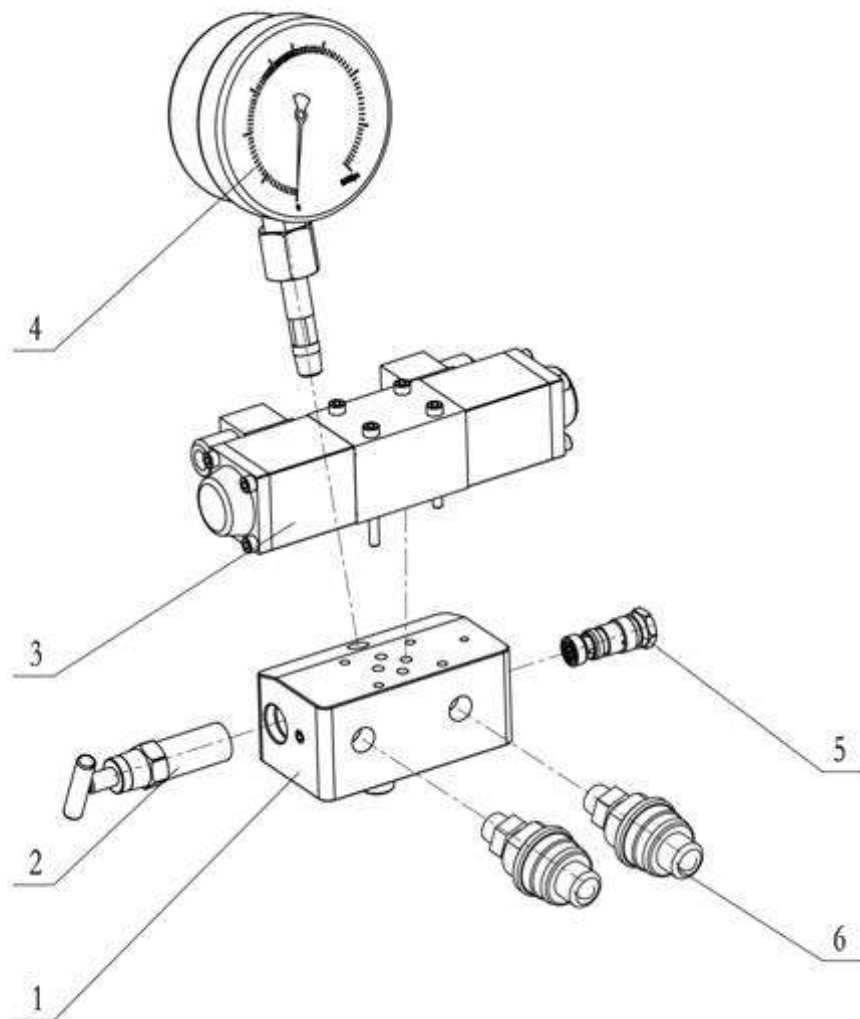

8		16	
7		15	
6	Male connector	14	
5	Low pressure relief valve	13	
4	Pressure gauge	12	
3	Solenoid valve	11	
2	High pressure relief valve	10	
1	Valve block	9	
No.	Name	No.	Name

# XI. Hydraulic Schematic Diagram of Pump Station

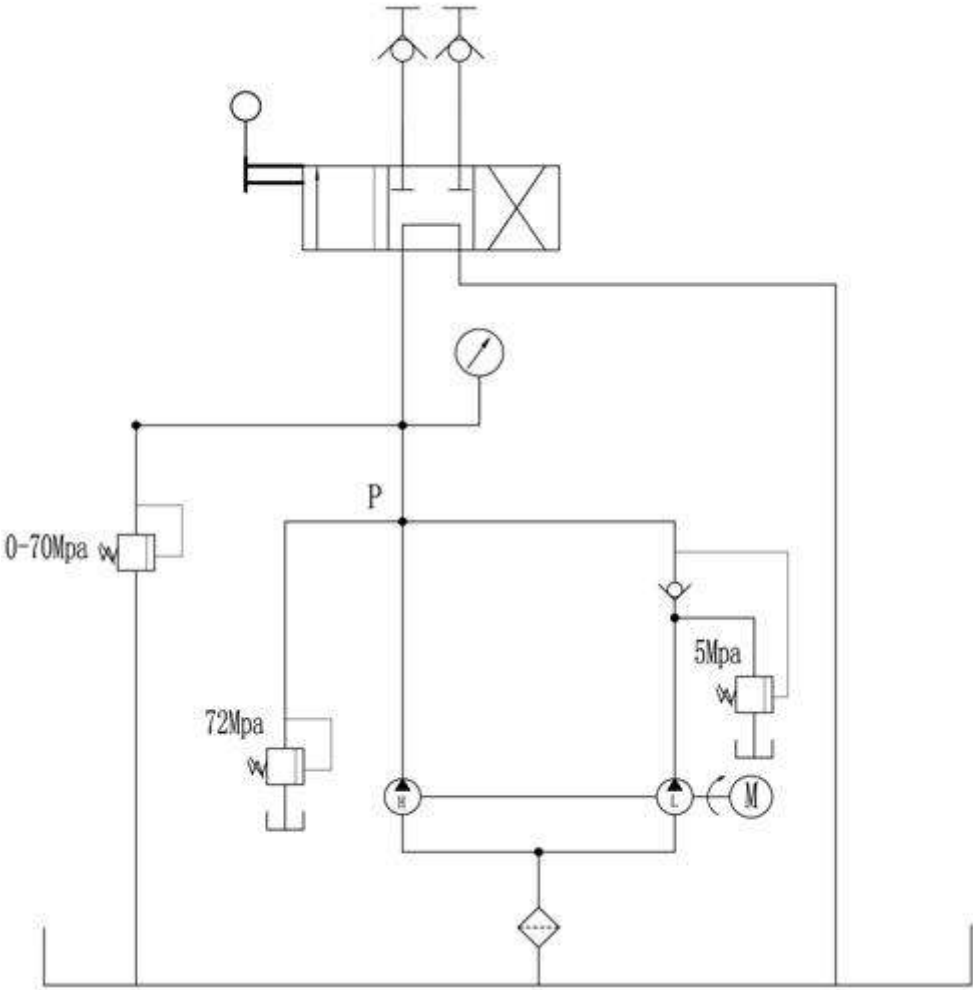

Schematic Diagram

## **XII. Transport**

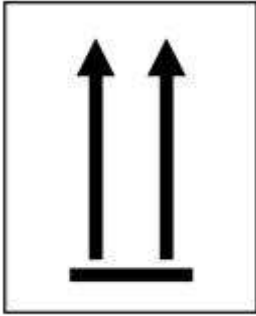

Transport precautions:

- 1) Handle with care during handling.
- 2) During loading and transport, face the product vertically upward and take the moist-proof measure, as shown in the figure:

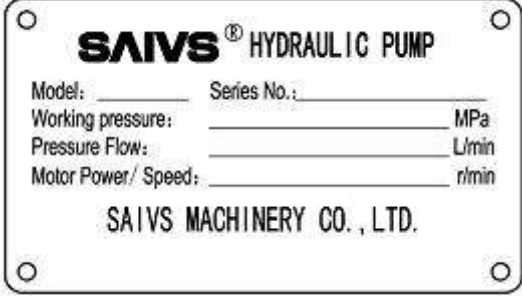

- 3) Generally, handle the product by hand or trolley.

### XIII. Warning Sign and Nameplate

Name	Description	Sticking location
Nameplate	 <p>SAIVS<sup>®</sup> HYDRAULIC PUMP</p> <p>Model: _____ Series No.: _____</p> <p>Working pressure: _____ MPa</p> <p>Pressure Flow: _____ L/min</p> <p>Motor Power/ Speed: _____ r/min</p> <p>SAIVS MACHINERY CO., LTD.</p>	On oil tank cover plate
Warning sign	 <p><b>WARNING</b></p> <p>Please read instruction book and warning carefully before operating equipment.</p> <ol style="list-style-type: none"> <li>1. Operating before quick coupling is forbidden when the pumping station is running.</li> <li>2. Over pressure is prohibited in the pumping station.</li> <li>3. Oil-free operation is prohibited. It will scrap equipment.</li> <li>4. Do rigid inspection of the connection of pipelines before operating equipment.</li> <li>5. Ensure that the power is well-grounded. Please avoid getting an electric shock.</li> <li>6. Non-professional people are forbidden to service equipment.</li> </ol>	Front face of electric box

**Note:**

- 1. Our company reserves the modification right for these operation instructions of super-pressure pump without further notice.**
- 2. For more detailed information, please contact our company.**

**Ningbo Saivs Machinery Co., Ltd.**

Postal code: 315135

Tel.: +86-574-88067629

+86-574-88344911

Fax: +86-574-88345368

Website: [www.saivs-industrial.com](http://www.saivs-industrial.com)