

Operation Instructions

SWP Series Hydraulic Torque Wrench Pump

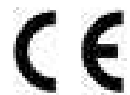

Please read these instructions carefully before operating. And keep instructions properly for future reference.



These instructions contain warnings, precautions, operation practices, and troubleshooting for special series pump station for hydraulic torque wrenches.

These operation instructions are only for the reference of the end users.

I. Receiving Notice (Unpacking Inspection)

Visually inspect all components for shipping damage. Shipping damage is not covered by warranty. If shipping damage is found, notify carrier at once. The carrier is responsible for all repair and replacement costs resulting from damage in shipment.

II. Overview

The SWP special hydraulic torque wrench pump is a kind of independently integral hydraulic device assembled in integrated mode and is composed of power unit, electric units, and control devices, featuring high flow, small volume, light weight, simple structure, easy operations, high operating pressure, and high energy-saving and environmental-friendliness, with the efficiency improved by >50% than conventional two-stage pumps.

1. The external motor starter switch eases the remote operations.
2. The external high-power radiator can guarantee the long-term continuous working without interruption.
3. The special integrated circuit board can realize automatic stop without operation in 1min and automatic pressure relief after stop.
4. The special pressure regulator valve can guarantee the long-term continuous working, with stable pressure.
5. The brushless motor installed features maintenance-free and long service life.
6. It features automatic switchover among three flows and three pressure outputs.
7. Two output pressures are provided, of which the high pressure output port (port A) is fitted with high pressure relief valve adjustable within 7~70MPa and the low pressure output port (port R) is fitted with low pressure relief valve regulated at 7MPa at the time of delivery.

III. Safety Instructions

Safety First

The special hydraulic [torque](#) wrench pump station is a power source. Before use, please carefully read all [instructions](#), warnings, and precautions and abide by the safety measures to prevent personal injuries and equipment damages during operations. SAIVS will not be liable for any damage arising from unsafe or incorrect operations. In event of abnormality during operations, please turn off the power switch (or cut off the air source), unplug the power connector, and then consult with SAVIS or SAIVS' authorized dealer.

Please ensure to abide by the following precautions and warnings.

Precautions

1. [The hydraulic pump is connected by high pressure hoses, quick couplings, and wrenches. Please use the SAIVS supplied high pressure hoses, quick couplings, and hydraulic wrenches.](#)
2. The used scrap hydraulic oil is an industrial waste. Please have it collected and disposed by an industrial waste processing company.
3. Operating environment: Please operate this pump indoors whenever possible. For outdoors applications, ensure to take the rainproof measures. Keep the operating environment as clean and bright as possible. If the air in the operating site contains any potential explosion risk, use an explosion-proof electric pump or pneumatic pump.
4. [Power supply: Please ensure that the input voltage of the hydraulic pump is consistent with the operating voltage in the site. The input power of the single-phase power supply shall be at least 3 times of the power of the pump station and the input power of three-phase power supply shall be at least 9 times of the power of the pump station.](#)
5. [Hydraulic oil selection](#): The hydraulic pump adopts 32# wear-resistant hydraulic oil and the working environment temperature is -10~60°C. Under the temperature of <0°C, to prevent the hydraulic oil from freezing the pump, warm up the pump for 10~30min before use. To use this product under -10~-30°C temperature, please replace with corresponding low trademark hydraulic oil.

Warnings

1. During running of the hydraulic pump, all personnel must keep away from hydraulic oil outlet, in order to prevent the potential personal and property loss in event of leakage of hydraulic oil. Keep it away from fire source.
2. Before applying the pressure, ensure to install hose or quick coupling to prevent the spray of high pressure oil from causing personal injuries.
3. The maximum operating pressure of this hydraulic pump station is 70MPa. The low pressure relief valve is set as 7MPa before delivery. It's prohibited to adjust the pressure beyond this value.
4. To operate other equipment by this pump station, it's necessary to adjust the pressure of this pump to the operating pressure of the equipment (The regulated pressure must be less than the maximum operating pressure of this hydraulic pump).
5. Cut off the power supply (air source) before repairs.
6. Ensure the grounding of this pump to prevent electric shock.
7. It's prohibited to start the hydraulic pump station without oil, otherwise it will cause equipment damage.
8. Adjust the relief valve to 0MPa before adjusting the pressure and ensure to increase gradually the pressure during the pressure test.
9. It's prohibited to refit this pump station. All refitting works without the written consent of SAIVS will not be covered by warranty scope. In event of special needs, please consult with SAIVS or SAIVS' authorized dealer.
10. Immediately stop using this pump station if the temperature of pump station exceeds 85°C. Wait for the pump station to cool, otherwise it will impair the life of the pump station.
11. Do not fill the oil to be above the capacity of the oil tank, otherwise the hydraulic oil will overflow to pollute the environment and equipment.
12. When the pressure regulator valve is not to be used for a long time, completely loosen the relief valve to prolong the service life of valve.
13. Ensure the complete engagement (Figure 1) while connecting the quick coupling, in order to ensure that the check valve in the connector is opened to prevent oil line blockage. Otherwise, the check valve in the connector can't be opened after connection to obstruct the oil line, in which case the pump station is pressurized after the application of pressure and the wrench

can't work to probably damage the quick coupling and wrench and even cause personal injuries. For quick coupling, directly insert the male connector into the female connector to the end and then tighten the sleeve. In such case, if the connector can't be inserted to the end, press the [directional control valve](#) to unload (Figure 6) and relieve the pressure from the connector, till the steel ball in the connector can be pushed down by hand.

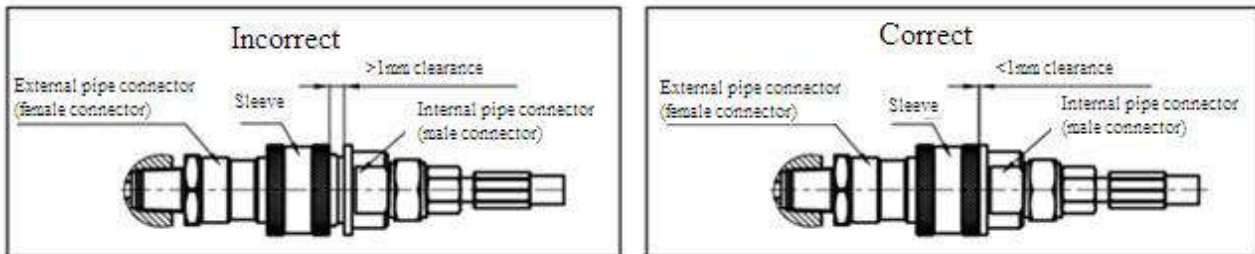
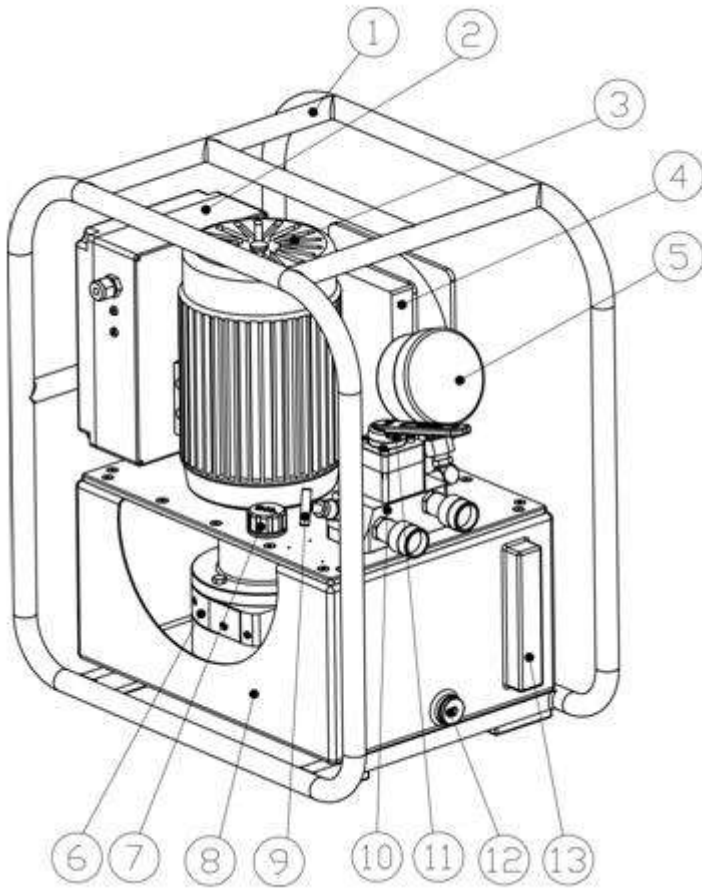

Figure (1)

14. [Ensure to keep clean the hydraulic pump station, installed equipment cylinder, and internal pipeline of high pressure hoses, especially the oil outlet and the quick coupling. The dirty hydraulic oil is a main cause leading to malfunction of hydraulic pump.](#)
15. Use 30# or 46# wear-resistant hydraulic oil for the hydraulic pump. It's prohibited to use a hydraulic oil with oil content or corrosive to the steel or aluminum.
16. In event of splash of hydraulic oil into your eyes, flush with clean water immediately for at least 15min and then seek for medical treatment.
17. The hydraulic hoses are wearing parts and are vulnerable to aging and difficult to observe. Therefore, ensure to replace the hoses periodically.
18. Keep away from all positions with possible overflow of super-pressure hydraulic oil and never touch any pressurized hose. The spray of hydraulic oil will cause serious injuries.

IV. Exterior View of Pump Station and Overview of Main Parts



13	Level gauge	1
12	Drainage port	1
11	<u>Directional control valve</u>	1
10	Group valve	1
9	High pressure relief valve	1
8	Oil tank	1
7	Oil filler and ventilator plug	1
6	Pump head	1
5	Pressure gauge	1
4	Cooler subassembly	1
3	Motor (See nameplate for parameters)	
2	Electric box	
1	Protective cage	
No.	Name	Quantity

1. Protective cage: It's installed on the oil tank for carrying and protection of hydraulic pump.
2. Electric box: It's the electric control part of hydraulic pump to control the start of pressurization, high/low pressure switch over, and stop of pressurization of the hydraulic pump.
3. Motor: It's functioned as the power source (Choose an appropriate motor depending on the voltage and frequency of the operating site. Refer to nameplate for detailed parameters).
4. Pressure gauge: This pressure gauge indicates the operating pressure of hydraulic pump, with the measurement range at 100MPa and the accuracy at 1MPa.
5. Cooler subassembly: It's functioned to reduce the oil temperature during working of oil pump
6. Oil filler and ventilation plug: Oil filler port.
7. Pump head: This radial plunger pump realizes three-stage flow output.
8. Oil tank: It's functioned for storage of hydraulic oil (The oil tank must contain sufficient oil).
9. High pressure relief valve: Also referred to as pressure regulator valve, this relief valve adjusts the operating pressure of hydraulic pump (The maximum operating pressure is limited at 70MPa at the time of delivery. It's prohibited to adjust the pressure above this maximum

pressure).

10. Drainage port: It's functioned to drain the hydraulic oil from the oil tank (during replacement of hydraulic oil).
11. Low pressure relief valve: it controls the pressure of outputted low pressure oil. (The pressure is set as 8MPa before delivery. It's prohibited to increase this pressure setting).
12. Level gauge: It's functioned to observe the level of hydraulic oil, in order to guarantee the supply of the optimal oil volume.
13. Group valve: The diversified types of hydraulic control valves in the hydraulic system are connected to realize the control on the output and return of the hydraulic oil and guarantee the normal working of system under preset pressure
14. Directional control valve: It realizes the reversing function for output and return of high and low pressure hydraulic oil and the unloading function.

V. Operation Procedure

1. Preparations

- 1) Oil level: Check the pump oil level before start. If the oil level reaches the maximum level of the level gauge (12) (Figure 2), it indicates that the oil tank is full. When the oil level drops to the minimum level, it indicates that the oil refilling is required. In such case, open the oil filler and ventilation plug (6) and slowly add the oil of appropriate volume.

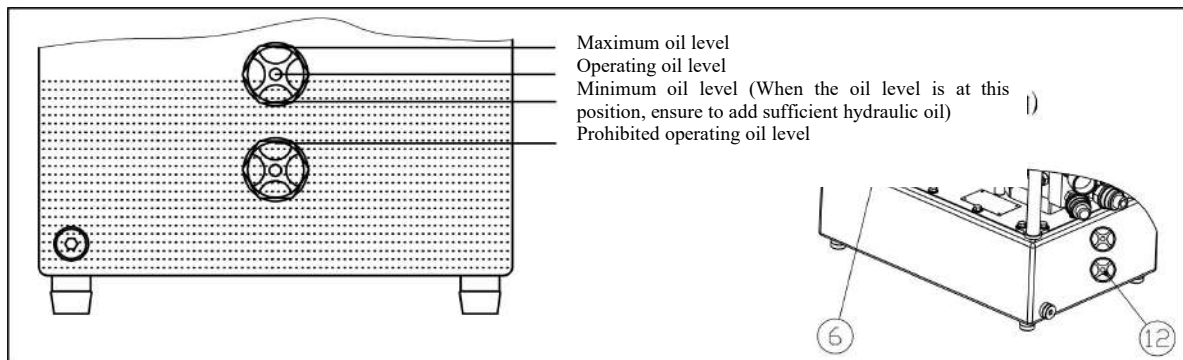

Figure (2)

- 2) Motor: Please provide the power supply as per the designated voltage on the pump nameplate or motor nameplate.

Start of motor: Connect the power supply, press the [POWER] button of the handle to power on the motor and press the [ON/OFF] button of the handle to start the motor (Figure 4).

Stop of motor: Press the [POWER] button of handle to stop the rotation of motor and unplug the plug to power off the motor.



Notice: The pump is capable of automatic stop without operation in 1min and automatic pressure relief after stop. After the stop of the motor, ensure to wait for approximately 10min before restarting the motor.



Notice: The motor is fitted with overload protection device.

- 3) Prestart: The prestart is required for the first operation or after oil replacement or long-term non-use of pump station, or under cold weathers. Loosen the pressure regulator valve (9) counter-clockwise to fully relieve the oil. Start the motor, press the [ON/OFF] button of the handle once a minute to run the pump station under no-load condition for a while. After the air content in the pump is fully bled, the oil pressure is stable, and there is no abnormality, the pump can be put into operation.

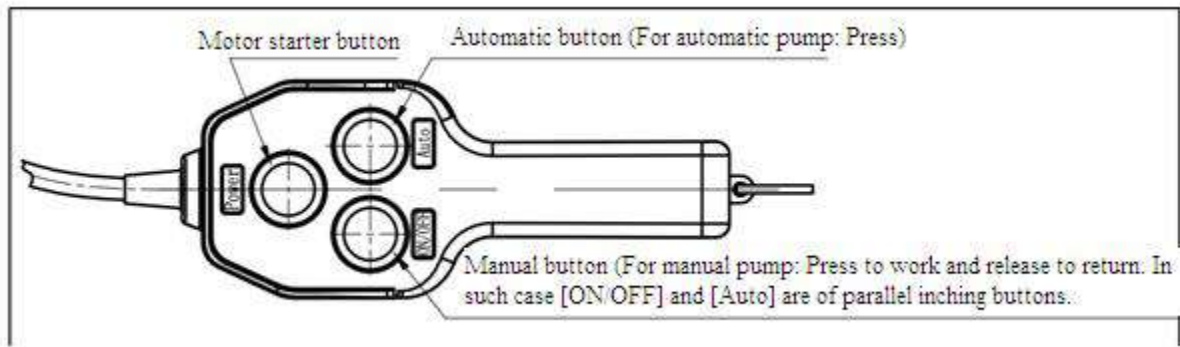

Figure (4)

- 4) Connections of oil lines: Connect the high pressure port (port A) of pump to the high pressure port (port A) of hydraulic **torque** wrench and the low pressure port (port R) of pump to low pressure port (port R) of hydraulic **torque** wrench respectively by 70MPa high pressure hoses (Figure 5). Ensure that the quick couplings are connected properly before operations (Figure 1).

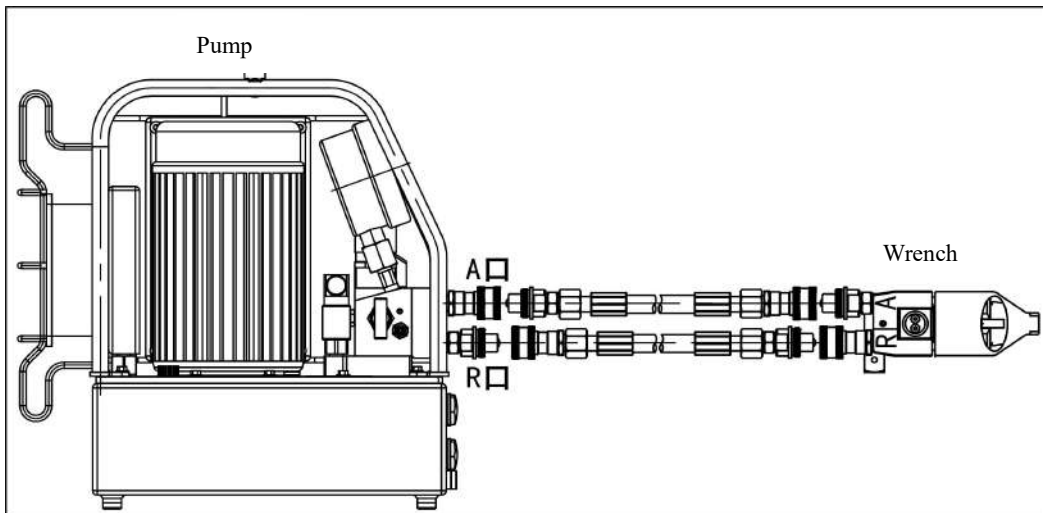

Figure (5)



Notice: Do not loosen any high pressure oil hose during working of pump.



Notice: Do not connect the oil **hoses** while the motor is running.

2. Adjustment of pressure

- 1) Pressure regulation: After the start of motor, completely loosen counter-clockwise the handle of pressure regulator valve (9). In such case, the pressure is almost zero. Then, depress and hold the button of [ON/OFF] and at the same time rotate the handle of pressure regulator valve (9) clockwise to increase the pressure gradually to your desired value.

- 2) Pressure verification: After the proper adjustment of pressure, press the button of [ON/OFF] again to verify the pressure.



Notice: When the pump is not to be used for a long time, completely loosen the pressure regulator valve counter-clockwise to prolong the service life of valve.



Warning: Adjust the pressure before placing the wrench onto the head of nuts or bolts. The pressure setting of the pump shall not exceed the pressure required to meet the demanded torque. Exceeding the demanded torque will probably damage the equipment and cause serious personal injuries.

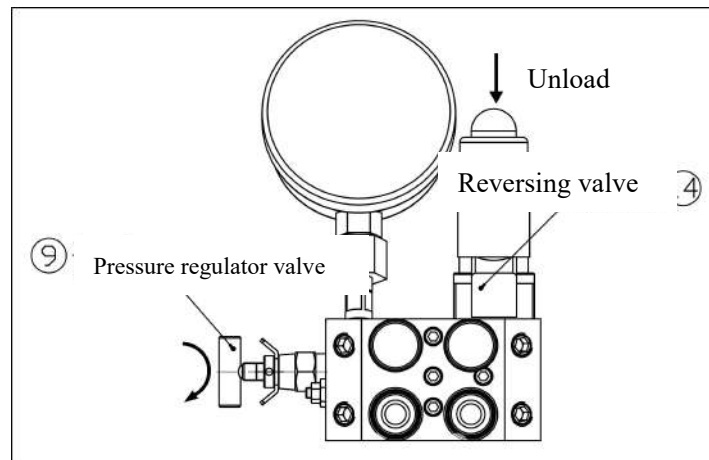

Figure (6)

3. Operations

- 1) Operation of wrench: After the above-mentioned preparations and pressure regulation, press the [Auto] button (for automatic pump) to realize the automatic operating and return of hydraulic torque wrench. For hand pump, press and hold the [ON/OFF] button so that the pump station outputs high pressure oil to operate the wrench. Release the button so that the pump station outputs low pressure oil to return the wrench.
- 2) At completion of operation: Press [Power] button to stop the pump station. In such case, the pump station is capable of automatic unloading function. If no pressure relief is performed, manually push down the directional control valve (14) to relieve the residual pressure from the hoses and equipment (Figure 6). Unplug the connector, cut off the power supply, and disassemble the high pressure hoses and install the dust caps.

VI. Maintenances

1. Maintenances before operations

- 1) Before operations, check all electric parts for presence of looseness and poor contact. If yes, repair immediately.
- 2) Check the motor for proper grounding. Ensure that the motor is reliably grounded.
- 3) Check whether the operating voltage in the site is within $\pm 10\%$ of the specified voltage of the hydraulic pump and whether the voltage is stable. If the operating voltage is below the specified voltage of the pump station, the pump station will automatically cut off power supply due to under-voltage protection.
- 4) Check whether the hydraulic oil level reaches the specified level. If insufficient, timely add hydraulic oil.
- 5) Check the piping and equipment for presence of oil leakage. In event of oil leakage, determine the cause and treat accordingly.
- 6) Upon detection of electric leakage in the equipment, immediately turn off the power supply and solve the malfunction before use, otherwise it will cause personal safety accidents.

2. Maintenances during operations: Upon detection of any abnormality in the following checking items, immediately stop the pump station for treatment.

- 1) Check for presence of abnormal noise, vibration, and smell and check for presence of clearly reduced speed during the working of motor (pneumatic motor).
- 2) Check for presence of abnormality during the pressure rise.
- 3) Check the hydraulic oil for over-high temperature.
- 4) Check the piping and equipment for the presence of oil leakage.
- 5) Check for serious pressure pulsation ($>5\text{MPa}$).
- 6) Check for reduced rotation speed under high pressure.

3. Maintenances after operations

- 1) Ensure to cut off the power supply after operations.
- 2) Check for presence of oil leakage. Upon detection of any abnormality, determine the cause and treat accordingly.
- 3) After the operations, clean the pump station and install dust caps to quick couplings.

VII. Replacement of Hydraulic Oil

1. Replace the oil after the first 100 working hours and afterwards replace the oil once every 300 working hours. Before oil replacement, fully drain the oil from the oil tank and clear up the oil tank. Under severe working environment, shorten the oil replacement interval depending on the actual conditions.

Detailed operations: Open the oil filler and ventilator plug (6) on the hydraulic pump, unscrew the drainage plug (10) from the side drainage port of oil tank to fully drain the hydraulic oil into an appropriate container, and then clean and reinstall the drainage plug (Figure 7).

2. When necessary, disassemble the oil tank and clean the inside of oil tank and the pump head filter screen.

Detailed operations: Unscrew 18 connecting screws between oil tank cover plate and oil tank body. In such case, the entire pump head can be taken from the oil tank. Disassemble the pump head filter screen, clean the filter screen by solvent and a soft brush, and then reinstall the cleaned filter screen.

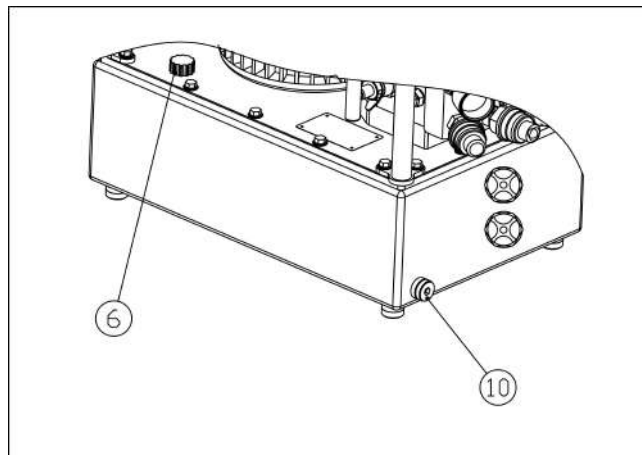

Figure (7)

VIII. Specification

Model	Name	Flow (high/medium/ low) L/min	Pressure (High/medium/ low) MPa	Motor power	Standard power cable length (m)	Net weight (Kg)	Capacity of oil tank (L)	Oil outlet/return interface	Overall dimensions (mm)
SWP6 Series	Special hydraulic <u>torque</u> wrench pump	0.65 / 1.5 / 5.8	70/30/7	0.9KW	5	28	7	NPT1/4	490X305X4 95
SWP6 Series	Special hydraulic <u>torque</u> wrench pump	0.8 / 1.6 / 7	70/30/7	1.1KW	5	28	7	NPT1/4	490X305X4 95
SWP8 Series	Special hydraulic <u>torque</u> wrench pump	1.4/2.8/4.5/15	70/40/25/7	2.2KW	5	35	7	NPT1/4	500X330X5 30

IX. Troubleshooting

Symptom	Malfunction analysis	Solution
Start failure of pump station	1. Inconsistency between voltage and specified voltage of this pump station	1. Ensure the consistent voltage
	2. No power supply for motor	2. Check all parts and ensure that the power supply is supplied.
	3. Damage of motor	3. Replace motor
No system pressure	1. No oil or insufficient oil in oil tank	1. Add hydraulic oil to specified level.
	2. Low pressure setting of relief valve	2. Adjust relief valve to required pressure.
	3. Blockage due to dirty oil	3. Replace hydraulic oil and clean hydraulic pump and filter screen.
	4. No oil suction of plunger pair	4. Open air bleeding valve (AIR VENT) to bleed air from pump head and ensure that the pump head is full of hydraulic oil (See Air Bleeding in Operation Procedure).
Failure of rated system pressure	1. Low pressure setting of relief valve	1. Adjust to rated pressure.
	2. Serious wear of plunger pair	2. Replace plunger pair.
	3. Serious wear of <u>directional control valve</u> core	3. Replace <u>directional control valve</u> .
	4. Damage of relief valve	4. Replace relief valve.
	5. Air content in system	5. Operate repeatedly to fully bleed air.
	6. Blockage of <u>directional control valve</u> by dirt	6. Clean <u>directional control valve</u>
Unstable system pressure	1. Dirty oil	1. Clean pump station and replace hydraulic oil.
	2. Damage of relief valve	2. Replace relief valve.
	3. Serious wear of plunger pair	3. Replace plunger pair.
	4. Air content in system	4. Operate repeatedly to fully bleed air.
	5. Blockage of <u>directional control valve</u> by dirt	5. Clean <u>directional control valve</u>
Continuously high pressure of full-automatic hydraulic wrench pump <u>torque</u>	1. The downstream backpressure of the high pressure relief valve is too low so that the pressure switch can't be detected and can't be closed to cause continuous electrification of solenoid valve and continuously high pressure.	1. Adjust backpressure.
	2. The flow of pump station is insufficient to form such a high backpressure to cause working failure of pump station.	2. Reduce damping orifice.
Continuously low pressure of full-automatic hydraulic wrench pump <u>torque</u>	Ensure that the pressure is 10MPa under low pressure state.	1. Adjust the pressure of pump station to >35MPa.
Slow return speed of		1. Replace with shorter oil hoses.

driven wrench		2. Adjust appropriately the changeover pressure of the high/low pressure changeover valve (no higher than 6MPa, for SWP3000 pump only).
---------------	--	---

Note: If the above-mentioned problems can't be solved, please timely contact SAIVS or SAIVS' authorized dealer for troubleshooting by professionals.

X. Explosive View of Hydraulic Pump

Assembling Explosive View of Hydraulic Pump

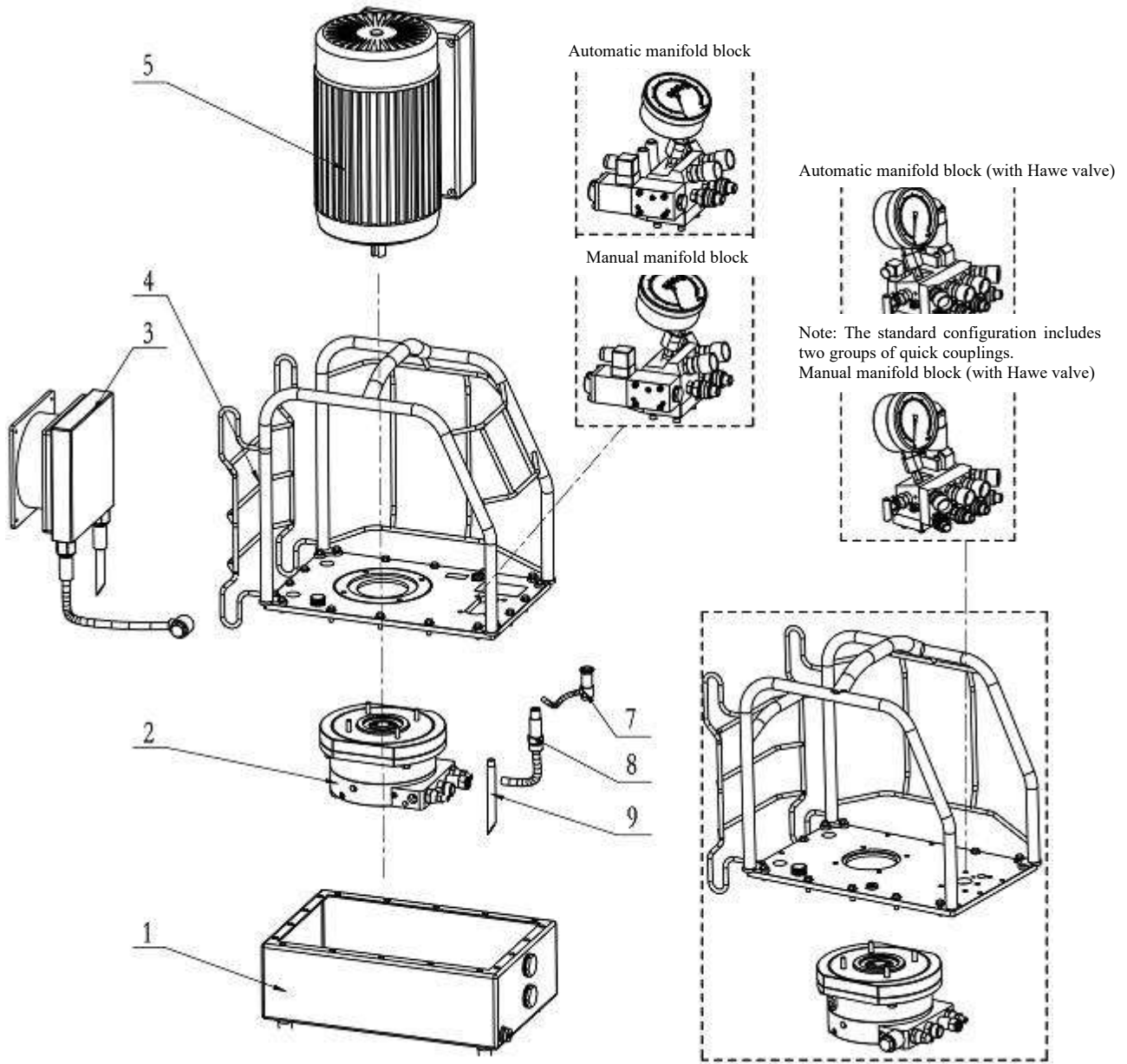

5	Electronic control system subassembly	10	
4	Protective cage	9	Fuel return hose
3	Air cooler subassembly	8	Oil inlet hose
2	Pump head	7	Ventilation hose
1	Oil tank subassembly	6	Integrated subassembly
No.	Name	No.	Name

Explosive View of Pump Head

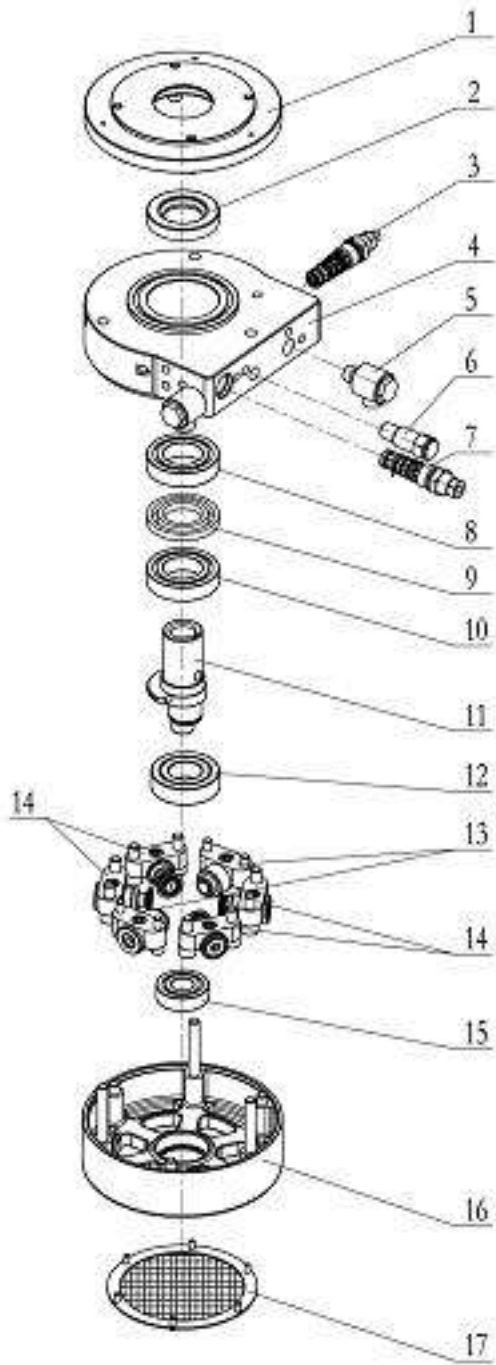

No.	Name
1	Flange
2	TC framework oil seal
3	Base
4	High/medium pressure switchover valve
5	Two-way connector
6	Safety valve
7	High/low pressure switchover valve
8	Deep groove ball bearing
9	Washer
10	Deep groove ball bearing
11	Crankshaft
12	Cylindrical roller bearing
13	Plunger pair 1
14	Plunger pair 2
15	Deep groove ball bearing
16	Bearing block
17	Filter screen

Explosive View of Manifold Block (with Hawe valves)

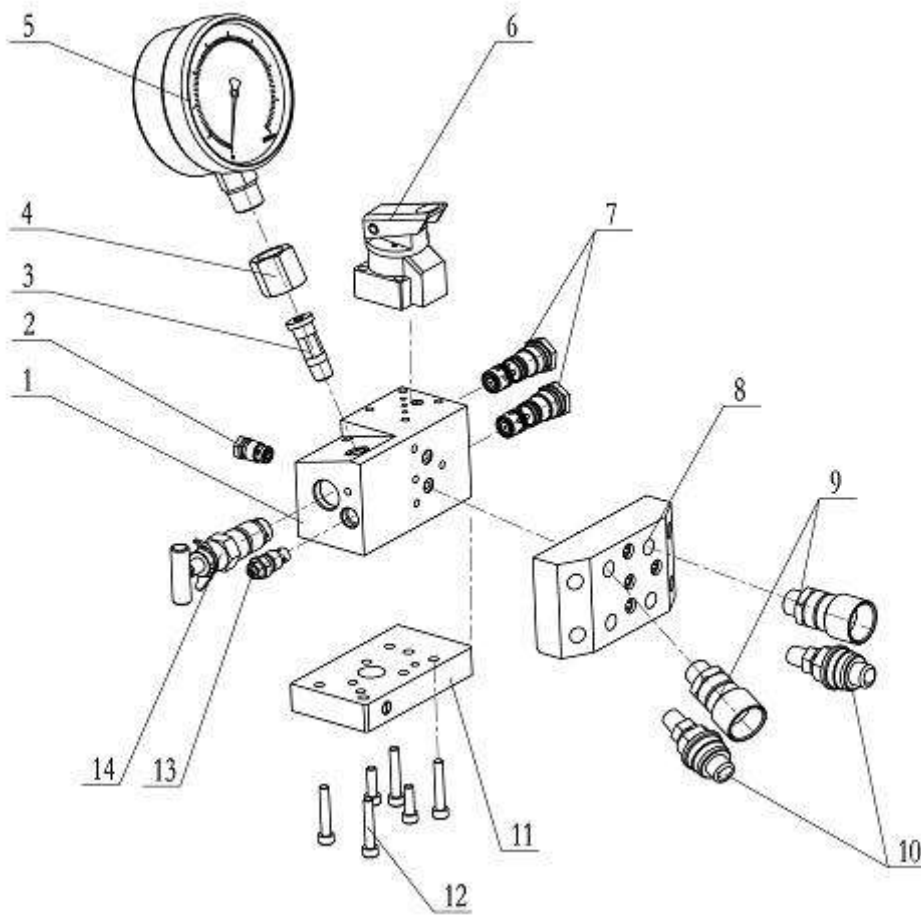

8	Quick coupling mounting plate	16	
7	Hydraulic directional control valve	15	Stroke switch (installed for automatic valve and not installed for manual valve)
6	Ball valve (Hawe)	14	High pressure relief valve
5	Pressure gauge	13	Low pressure relief valve
4	Nut	12	Hexagon socket cylindrical head screw M6*20
3	Pressure gauge connector	11	Transition plate
2	5-way check valve	10	Male connector
1	Valve block	9	Female connector
No.	Name	No.	Name

Explosive View of Manifold Block

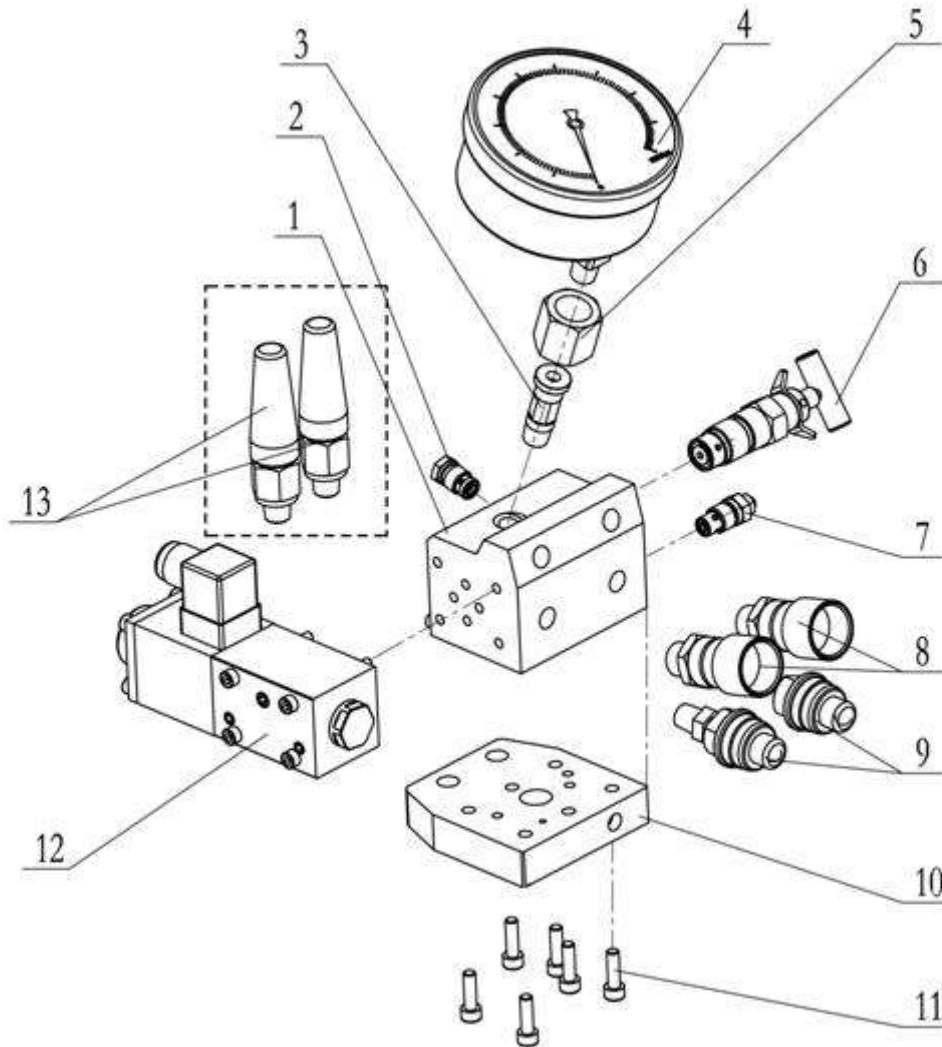

8	Female connector	16	
7	Low pressure relief valve	15	
6	High pressure relief valve	14	
5	Nut	13	<u>Stroke</u> switch (installed for automatic valve and not installed for manual valve)
4	Pressure gauge	12	Two-position four-way <u>solenoid directional control valve</u>
3	Pressure gauge connector	11	Hexagon socket cylindrical head screw M6*20
2	5-way check valve	10	Transition plate
1	Valve block	9	Male connector
No.	Name	No.	Name

XI. Hydraulic Schematic Diagram of Pump Station

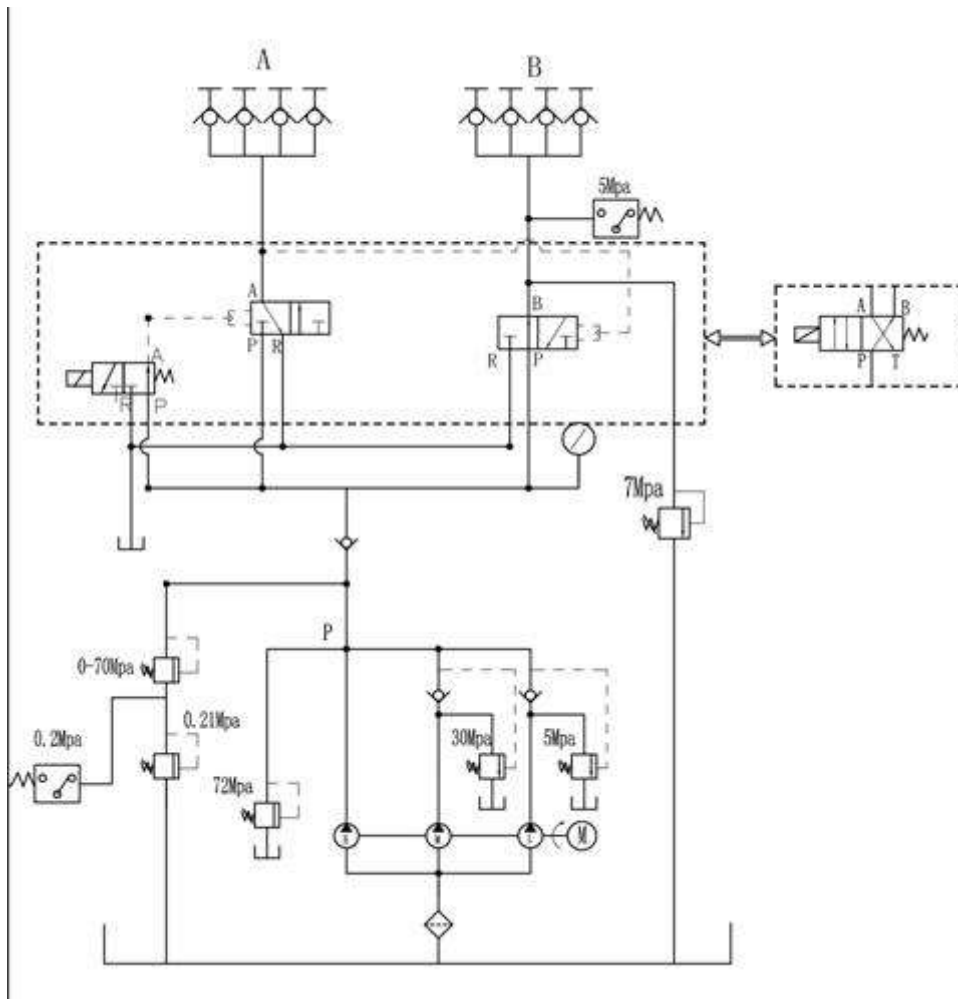

Notice: The above parameters are the settings before delivery, of which the high pressure relief valve at port A can be set by the customer depending on own demands and other parameters are prohibited for adjustment.

XII. Electrical Schematic Diagram

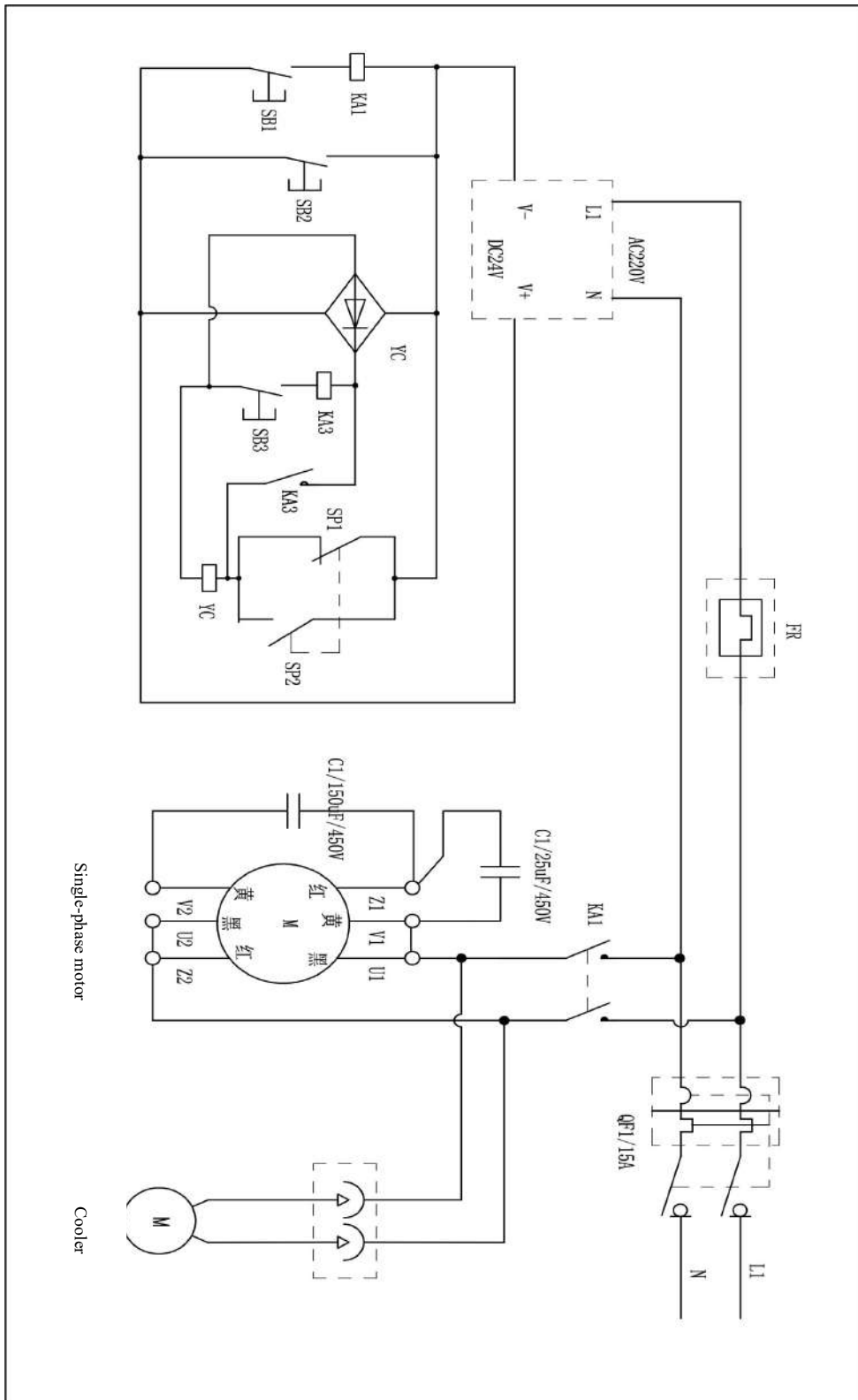

XIII. Control Block Wiring Diagram

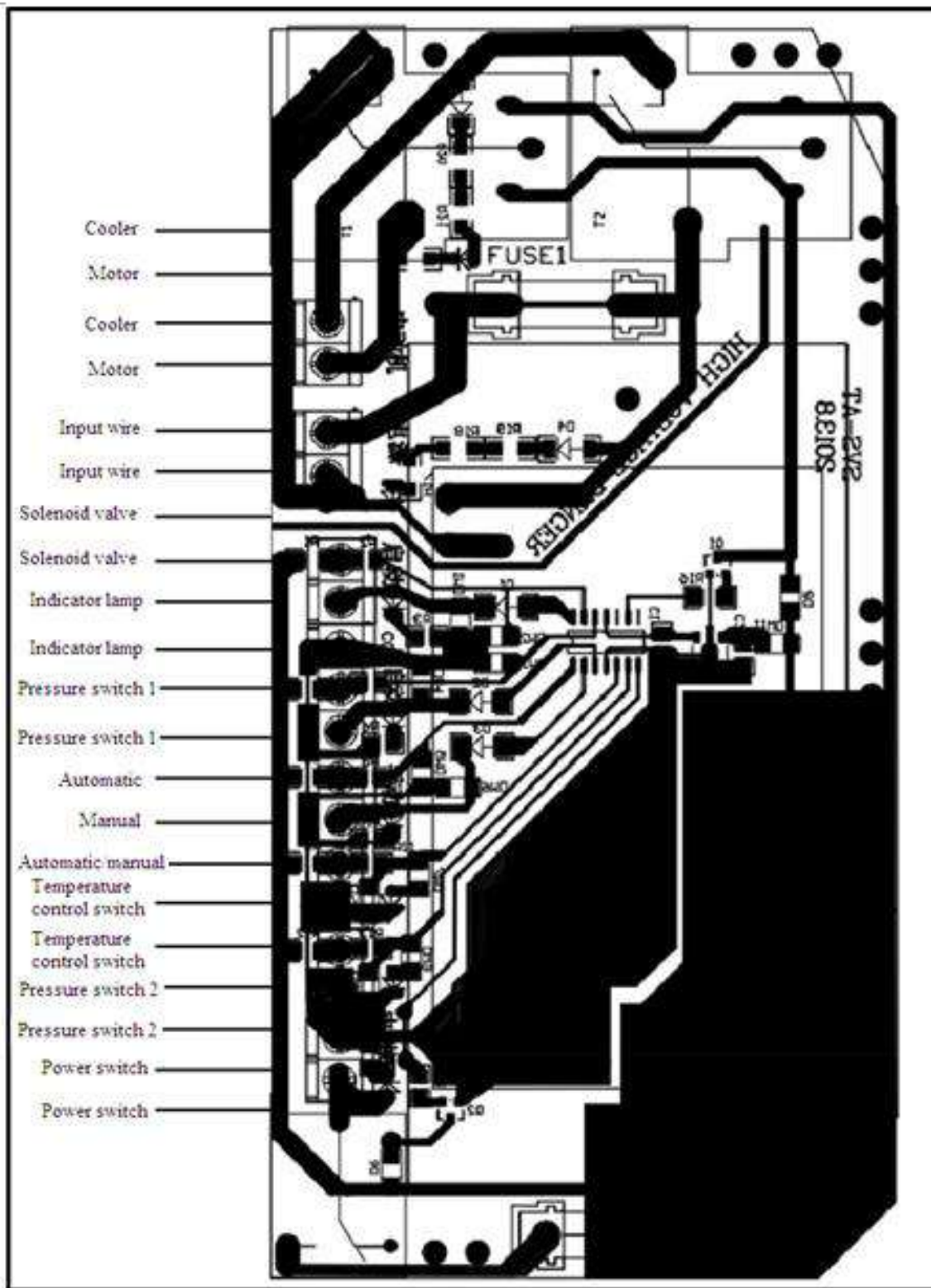

XIV. Transport

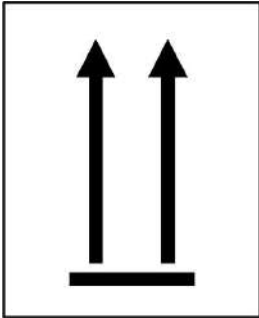

Transport precautions:

- 1) Handle with care during handling.
- 2) During loading and transport, face the product vertically upward and take the moist-proof measure, as shown in the figure:

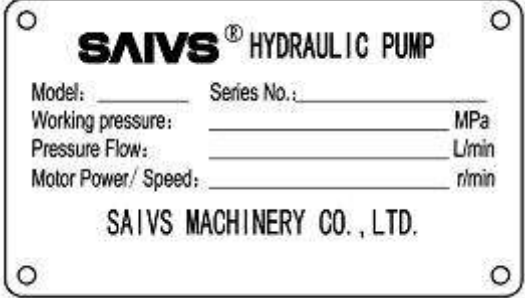

- 3) Generally, handle the product by hand or trolley.

XV. Warning Sign and Nameplate

Name	Description	Sticking location
Nameplate	 <p>SAIVS[®] HYDRAULIC PUMP</p> <p>Model: _____ Series No.: _____</p> <p>Working pressure: _____ MPa</p> <p>Pressure Flow: _____ L/min</p> <p>Motor Power/ Speed: _____ r/min</p> <p>SAIVS MACHINERY CO., LTD.</p>	On oil tank cover plate
Warning sign	 <p>WARNING</p> <p>Please read instruction book and warning carefully before operating equipment.</p> <ol style="list-style-type: none"> 1. Operating before quick coupling is forbidden when the pumping station is running. 2. Over pressure is prohibited in the pumping station. 3. Oil-free operation is prohibited. It will scrap equipment. 4. Do rigid inspection of the connection of pipelines before operating equipment. 5. Ensure that the power is well-grounded. Please avoid getting an electric shock. 6. Non-professional people are forbidden to service equipment. 	Front face of electric box

Note:

1. Our company reserves the modification right for these operation instructions of this hydraulic torque wrench pump without further notice.
2. For more detailed information, please contact our company.

Ningbo Saivs Machinery Co., Ltd.

Postal code: 315135

Tel.: +86-574-88067629

+86-574-88344911

Fax: +86-574-88345368

Website: www.saivs-industrial.com